

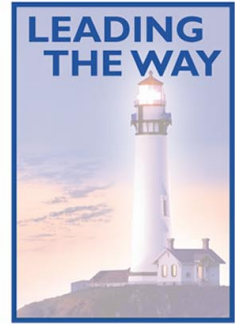

e-QD MARINE GENERATORS



17.0 kW e-QD 60 Hz
13.5 kW e-QD 50 Hz
e-Series™ Networked
Model MDKBP
Diesel

Leading the Way

- Rugged dependability, high quality, and innovation make Onan the leader in marine generator set design and development.
- The digital e-QD (electronic Quiet Diesel) Series models are the first marine gensets with self-monitoring capability and network communication.
- The optional e-Series Digital Display provides user-friendly diagnostics including extensive engine and alternator information, self-diagnostic features, and text display.
- Onan's advanced design and development process uses technology to lower sound and vibration. Our sound shields minimize noise and deliver better sound quality. The optimized mounting system greatly reduces vibration.
- Onan marine gensets are emissions certified to U.S. Environmental Protection Agency (EPA) emission standards.
- Onan has the largest worldwide certified Distributor/Dealer support network in the industry with more than 60 years of marine experience.

Genset Ratings

Model	kW/kVA	Voltage	Amps	Phase	Hz	Engine RPM
17.0MDKBP	17.0/17.0	120/240	141.7/70.8	1	60 Hz	1800
	17.0/21.2	120/208	59.0	3	60 Hz	1800
13.5MDKBP	13.5/13.5	110/220	122.7/61.4	1	50 Hz	1500
		115/230	117.4/58.7	1	50 Hz	1500
	13.5/16.9	120/240	112.5/56.3	1	50 Hz	1500
		220/380	25.6	3	50 Hz	1500

Other single and three phase configurations are available, contact your Distributor/Dealer for more information. Rating conditions are 100 kPa (29.6 in Hg) barometric pressure, 30% relative humidity and 25° C (77° F) (ref. ISO 3046).

Genset Dimensions and Weights

	Without Sound Shield	With Sound Shield
Length	44.4 in (1127 mm)	44.4 in (1127 mm)
Width	23.7 in (602 mm)	23.7 in (602 mm)
Height	26.1 in (664 mm)	27.5 in (698 mm)
Weight (dry)	830 lb (377 kg)	890 lb (404 kg)

Features

- Advanced digital electronic control providing extensive diagnostic capability
- Shutdown with diagnostic indicator light for
 - High engine coolant temperature
 - High exhaust temperature
 - Low oil pressure
 - Over speed
 - Over voltage
 - Starter overcrank
 - No raw water flow
 - Additional customer input and many more
- Electronic governor allows the genset to maintain isochronous frequency control and close voltage regulation to provide quality power for digital appliances and computers
- Switchable between 50/60 Hz
- Single phase AC alternator with single or dual voltages, brushless
- Digital voltage regulator integral with control
- 300% short circuit current capability
- 12 V DC electric system with battery charging, negative ground
- DC control console mounted with isolation and DC protective circuit breakers
- Start-run-stop switch with glow plug pre-heat and fuel pump priming modes for easy starting; run light and diagnostic indicator light
- Start function has automatic pre-heat to glow plugs providing better, cleaner starting
- Electric fuel transfer pump for priming and lift capability
- Engine starter with automatic start disconnect
- Freshwater cooling system with heat exchanger, expansion tank and coolant recovery system
- Water cooled exhaust mixing elbow
- Gear-driven raw water pump
- AC mainline circuit breaker
- Running time meter
- Air intake silencer
- Full flow lube oil filter
- Oil drain and hose extension
- Electric fuel shut-off via electronic governing actuator
- Fuel filter/water separator
- Drip pan base capable of containing all genset fluids
- Captive focalized mounting system with vibration isolator mounts
- Bulk head type connections for ease of installation include battery, ground connection (vessel bond), wet exhaust, raw water inlet, fuel in and out
- Single point lifting bracket for ease of installation
- Plug-in watertight connector for optional remote control
- Closed crankcase breather re-circulation to eliminate engine room contamination
- Coolant overflow bottle to easily maintain coolant level
- Fire extinguisher access port
- Factory load tested
- E-coat process to protect sheet metal
- Five year Limited Warranty

Available Options

- e-Series Digital Display - graphical LCD set-mounted display for genset operating parameters, diagnostics, and pre-alarm indication in text format
- SAE J-1939 CAN data link for monitoring generator set status and diagnostics for engine and alternator
- SmartCraft Networked™ data link for monitoring generator set status and diagnostics for engine and alternator (display available through Cummins MerCruiser Diesel)
- Low coolant level shutdown
- Keel cooling with wet exhaust
- Keel cooling with dry exhaust
- 12 V DC electric system with battery charging, isolated DC
- 3 phase, 125° C broad range alternator with a variety of voltages
- 24 V DC electric system with battery charging, negative ground
- 24 V electric system with battery charging, isolated DC
- Dry exhaust system (up or down orientation)
- Sound shield housing
- Front power take-off (PTO) for full engine output with clutch, flexible coupling and SAE B flange pump mounting for 2 and 4 bolt mounting; (12 or 24 V DC clutch)
- Engine end interface connections
- Engine end wet exhaust outlet
- Remote shut down harness for fire extinguisher connection



Standard Model without Sound Shield Shown.

Accessories

- e-Series Digital Display - graphical LCD remote display for genset operating parameters, diagnostics, and pre-alarm indication in text format
- Basic remote panel with start/stop switch with run (green) and control status (amber) lamps
- Remote start/stop switch with dual lamps and mating harness for panel installation
- 12 or 24 volt isolated ground conversion kit, no battery charging
- Y adapter harness for dual remote stations
- Remote station harness pigtail
- Remote panel wire harness - 15 ft, 25 ft, 45 ft, 75 ft, 100 ft or 150 ft
- Line circuit breakers for field conversion of frequency or AC voltage output
- Remote fuel filter/water separator assembly
- Fuel supply and return hose barb connectors
- Dry exhaust muffler, flexible exhaust stainless steel tube assembly
- Siphon break kit
- Wet exhaust hose and stainless steel elbow
- Battery
- Bulk head battery terminal boots
- Low coolant level shut down switch
- Front or rear exhaust outlet kit
- Dry exhaust fitting
- Marine mufflers, water separator, and resonator dual silencers
- Front power take-off (PTO) for full engine output with clutch, flexible coupling and SAE B flange pump mounting for 2 and 4 bolt mounting; (12 or 24 V DC clutch), additional sound shield front panel or belt guard is required
- Sound shield housing
- Cruise kit - maintenance parts - fuel filters, oil filters, raw water pump impellers, zinc pencils and alternator belt, plastic container
- Keel cooling conversion for wet or dry exhaust



e-Series Digital Display

Outline Drawing

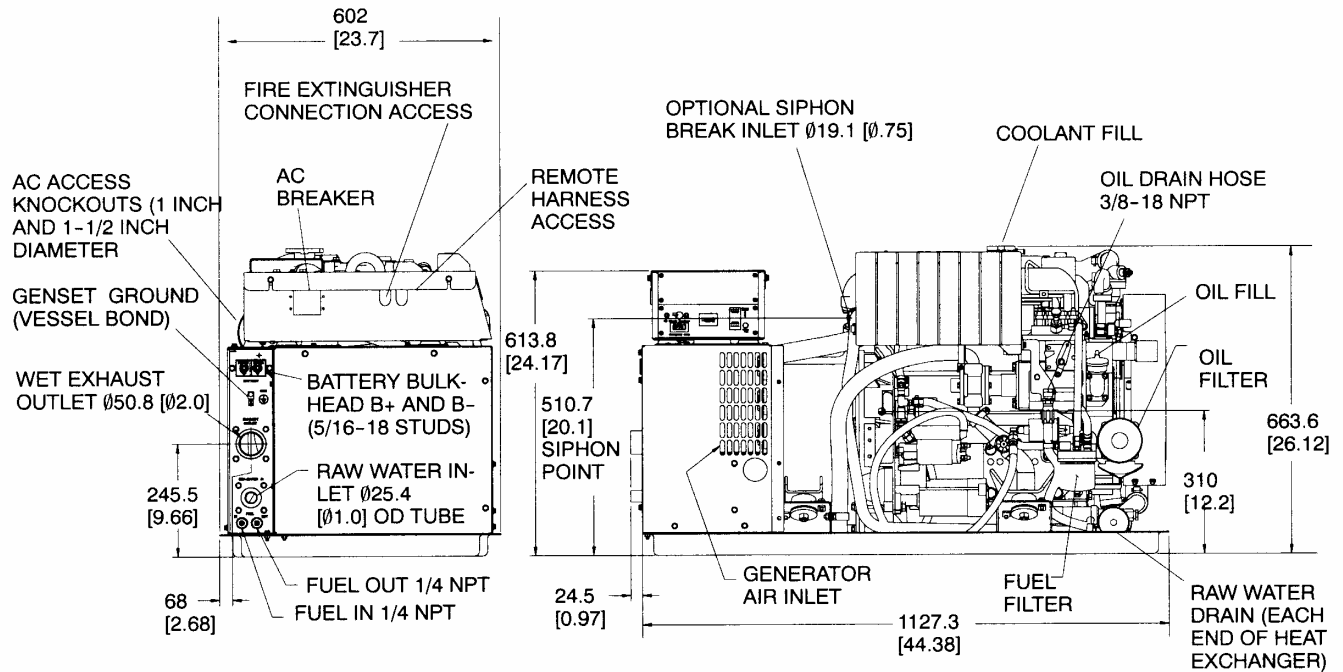

This outline drawing is provided for general reference only and is not intended for design or installation. See installation manual and obtain outline drawing number 500-3377 for more information (available from your Distributor/Dealer).

Engine Detail

Design 4-cycle, water-cooled diesel
Cylinders 4

Bore 3.15 in (80 mm)

Stroke 3.64 in (92.4 mm)

Displacement 113.32 in³ (1857 cm³)

Compression Ratio 23:1

Max Fuel Lift 4 ft (1.22 m)

Lube Oil Capacity 8 qt (7.6 L)

Coolant Capacity 8 qt (7.6 L)

Coolant Flow Rate

60 Hz: 14.0 Gal/min (53.0 L/min)

50 Hz: 10.0 Gal/min (37.9 L/min)

Raw Water Flow Rate

60 Hz: 9.0 Gal/min (34.1 L/min)

50 Hz: 7.0 Gal/min (26.5 L/min)

Starting System Remote 3-wire, 12 V starting battery required, 70 Ah, 500 CCA; 24 V optional

Power (Max) SAEJ1349

at 1800 RPM 31.2 hp (23.3 kW)

at 1500 RPM 26 hp (19.4 kW)

Fuel Injection Pump Bosch PFR-M mini

Combustion Chamber Spherical, three vortex combustion system

Max Raw Water Lift 4 ft (1.22 m)

Fuel Consumption

No. 2 diesel fuel, Gal/hr (L/hr)

	13.5 MDKBP 50 Hz	17.0 MDKBP 60 Hz
No Load	0.3 (1.1)	0.4 (1.5)
1/4 Load	0.5 (1.9)	0.6 (2.3)
1/2 Load	0.7 (2.7)	0.8 (3.0)
3/4 Load	0.8 (3.0)	1.0 (3.8)
Full Load	1.1 (4.2)	1.3 (4.9)

Alternator Detail

Design Onan brushless, revolving field, 4-pole alternator; rigidly coupled to engine and permanently aligned

Voltage Regulator Solid state, circuit board encapsulated for corrosion protection

Exciter System Brushless with 8-pole stator mounted in endbell; rotating rectifier assemblies are encapsulated for protection from adverse environments

Stator Skewed stator and 2/3 pitch windings minimize field heating and voltage harmonics; resin-coated for corrosion protection

Rotor Dynamically balanced assembly; direct-coupled to engine by flexible drive discs; supported by prelubricated, maintenance-free ball bearing

Cooling Direct drive centrifugal blower
Insulation System Class H per NEMA MG1-1.65 and BS 5000

Genset Detail

Operating Environment Gensets are durability tested at maximum ambient; air temperature: 122° F (50° C); raw water temperature 100° F (37.8° C)

Frequency Regulation Isochronous

Random Frequency Variation Will not exceed +/-0.5% of its mean value for constant loads from no load to full load

Voltage Regulation No load to rated load +/-1%

Random Voltage Variation Will not exceed +/-% of its mean value for constant loads from no load to full load

Sound Level

67 dB(A) at 60 Hz*

64 dB(A) at 50 Hz*

* Full load at 1 m with optional Onan sound shield

Warranty Policy

The Onan express, written Limited Warranty covers virtually everything except routine maintenance for the first two years you own your marine genset, and covers parts and labor on major power train and genset parts during the third through fifth years.

For complete Onan Limited Warranty details see your Onan Distributor/Dealer.

After Sale Support

GENUINE ONAN MAINTENANCE PARTS AND PRODUCTS - For your ongoing satisfaction and the dependability of your Onan marine genset, Onan offers a complete line of replacement and tune-up parts, accessories and oil and maintenance chemicals. Onan marine parts are packaged for correct selection and convenient on-board storage.

EASY TO LOCATE CERTIFIED ONAN SERVICE AND PARTS DEALERS - Onan has the largest and best-trained worldwide certified Distributor/Dealer network in the industry, offering on-time parts and service and installation assistance. Onan Distributor/Dealers stock and sell commonly used Onan marine genset maintenance parts, accessories and products, plus operator manuals and literature on current Onan gensets. They can help you select and install the right genset for a new vessel or accessories on older models, or provide answers to questions on proper operation and maintenance procedures.

MANUALS - Installation, operators and parts manuals are shipped with the genset. To obtain additional copies or other manuals for this model, see your Onan Distributor/Dealer.

Standards and Testing



National Marine Manufacturers Association (NMMA) members produce every conceivable product used by recreational boaters. NMMA provides a wide variety of programs and services including technical expertise, standards monitoring, government relations advocacy and industry statistics.

The American Boat and Yacht Council (ABYC) develops standards and recommended practices for designing, constructing, equipping and maintaining small pleasure and commercial craft.

This genset was designed and manufactured in facilities certified to ISO 9001.

Contact your Distributor/Dealer for more information



www.onan.com

Cummins Power Generation

1400 73rd Avenue N.E.

Minneapolis, MN 55432 U.S.A

1-800-888-ONAN or 763-574-5000

fax: 763-528-7242

email: feedback@onan.com

Onan is a brand of Cummins Power Generation, which is a subsidiary of Cummins Inc.

Onan, Cummins Power Generation, e-Series, e-QD, e-QG and "Leading the Way" are servicemarks, trademarks, and/or registered trademarks of Cummins Inc.

WARNING: Backfeed to a utility system can cause electrocution and/or property damage. Do not connect to building electrical except through approved device or after building main breaker is open.